

SOLLEVATORE ROVESCIAIORE DI VASCHE  
BOWL ELEVATOR TIPPER

# TC B - H



**Esmach S.p.A.**  
Via Vittorio Veneto 143  
36040 Grisignano di Zocco (VI) I

Tel. +39 0444 419777  
Fax +39 0444 419708  
[www.esmach.com](http://www.esmach.com)

**ESMACH** 

## CARATTERISTICHE FEATURES

- 1 Struttura in carpenteria pesante di acciaio verniciato a forno, con trattamento anti-corrosione e impiego di polveri epossidiche (contatto alimentare)
  - 2 Scivolo per pasta in acciaio inox
  - 3 Sistema di sollevamento e scarico con funzionamento oleodinamico
  - 4 Pannello comandi sollevatore con pulsanti a due mani, ad azione mantenuta.
- 
- 1 Structural steelwork painted with anti-corrosion treatment and epoxy coating (food contact).
  - 2 Stainless steel dough chute.
  - 3 Hydraulic lifting and tipping system
  - 4 Up-down movements by "hold-to-run" controls.



I sollevatori - rovesciatori di vasche TC sono impiegati per trasferire l'impasto dalle vasche delle impastatrici a carrello estraibile ISE/A - ISE/NA - SPI A - SPI A Hybrid, al banco di lavoro oppure all'interno di tramogge montate su spezzatrici volumetriche SP e DVP.

The TC bowl elevators-tippers are used to transfer the dough from the bowls of removable trolley mixers ISE/A - ISE/NA - SPI A - SPI A Hybrid to the work bench, or into hoppers fitted on volumetric dividers SP - DVP

Il pannello a pulsanti del sollevatore è del tipo "comando a due mani" ad azione mantenuta e comprende i comandi di salita e discesa.

The lifter panel has manual push buttons "hold-to-run" controls type and includes buttons for up-down movements.



## IL MOVIMENTO THE MOVEMENT

TC B in fase di scarico su banco di lavoro: una soluzione veramente compatta, che solleva dalla fatica del lavoro manuale senza compromettere lo spazio nel laboratorio.

TC B when tipping on a work table: a really compact solution that relieves from the strain of manual work without affecting space in the workplace.



TC B



TC H

TC H in fase di scarico su spezzatrice volumetrica: il tipico abbinamento per alimentare, con ingombri minimi, una linea automatica.

TC H when tipping onto a volumetric divider: the typical solution to feed an automatic line with minimal occupied floor space.

## TC H

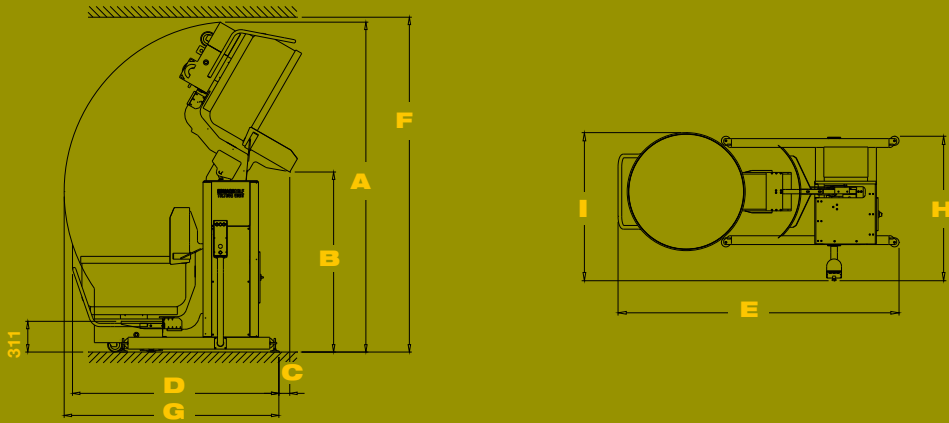

## ABBINAMENTI TYPE OF COUPLING

### TC HL

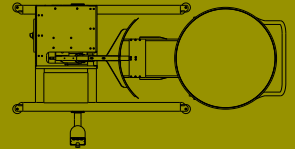

### TC HR

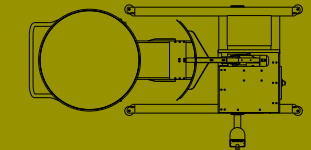

## TC B

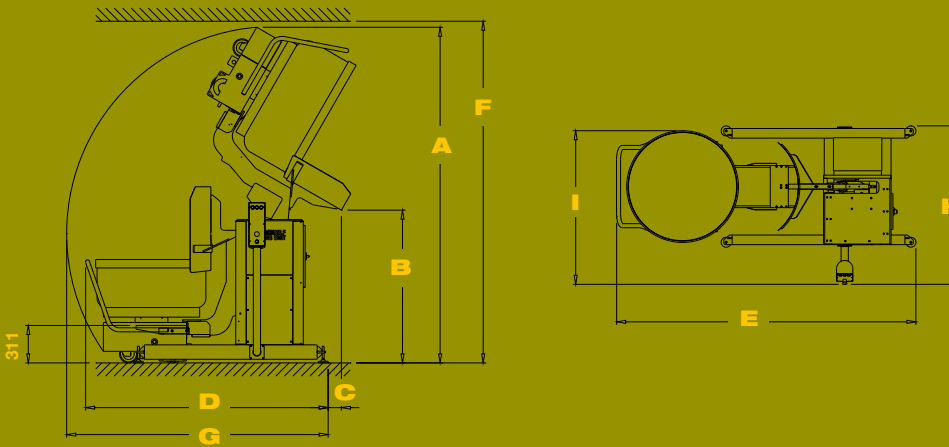

### TC BL

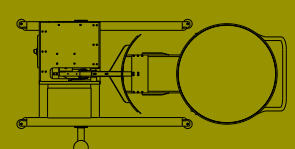

### TC BR

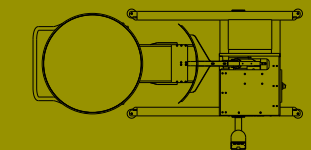

### Dati Tecnici/Technical features

		TC H		TC H		TC B		TC B	
		carrello / trolley		carrello / trolley		carrello / trolley		carrello / trolley	
		ISE NA / SPI A	ISE NA / SPI A	ISEA/SPIA HYBRID	ISEA/SPIA HYBRID	ISE NA / SPI A	ISE NA / SPI A	ISEA/SPIA HYBRID	ISEA/SPIA HYBRID
		160-200	250-300	160-200	250-300	160-200	250-300	160-200	250-300
A	mm	3340	3340	3364	3418	2789	2789	2814	2868
B	mm	1886	1822	1886	1822	1333	1269	1333	1269
C	mm	147	110	147	110	147	110	147	110
D	mm	2015	2087	1990	2058	2015	2087	1990	2058
E	mm	2487	2559	2461	2529	2487	2559	2461	2529
F min.	mm	3390	3390	3414	3468	2839	2839	2864	2918
G	mm	2172	2172	2192	2248	2172	2172	2192	2247
H	mm	1316	1316	1316	1316	1316	1316	1316	1316
I	mm	1276	1350	1276	1350	1276	1350	1276	1350
Potenza installata									
Installed power	kW	1,1	1,1	1,1	1,1	1,1	1,1	1,1	1,1
Potenza max assorbita									
Max. absorbed power	Kw	1,1	1,1	1,1	1,1	1,1	1,1	1,1	1,1
Connessione elettrica									
Plug coupling		3PH+Gr	3PH+Gr	3PH+Gr	3PH+Gr	3PH+Gr	3PH+Gr	3PH+Gr	3PH+Gr
Massa									
Weight	kg	725	725	725	725	420	420	420	420